

Filter Gitter

Model KF

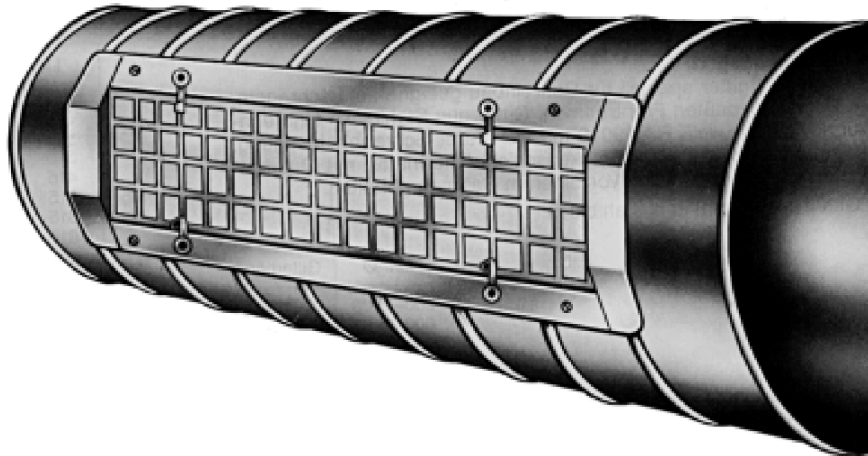

SCHAKO KG
Steigstraße 25-27
D-78600 Kolbingen
Telephone +49 (0) 74 63 - 980 - 0
Fax +49 (0) 74 63 - 980 - 200
info@schako.de
www.schako.de

Filter Grille KF

Contents

Description	3
Construction	3
Fastening	3
Models and dimensions	3
Dimensions	3
Installation	3
Technical Data	4
Pressure loss and noise level	4
Legend	4
Specification texts	4

Filter Grille KF

Description

Filter grille type KF for supply and return air particularly for direct fitting into round ducts, with front side fitted dry filter mat for easy cleaning and replacement.

Regeneration of the filter mat

Rinse in water (up to 40°C possibly with addition of a commercially available mild detergent). Beating, vacuum-cleaning or blowing compressed air through the filter are also possible. With fat dust types: rinse in petrol ether or warm water with the addition of P-3. Avoid wringing! When rinsing with water, avoid a sharp water jet! Temperature-resistant up to 100°C.

Construction

Filter insert grille

- Sheet steel painted to RAL 9010 (white)
- Galvanised sheet steel

Frame

- Sheet steel painted to RAL 9010 (white)
- Galvanised sheet steel

Dry filter mat

- Polyamide fibre

Fastening

Screw mounting (-SM)

- Standard, screws must be provided on-site

Concealed mounting (-VM)

- not possible!

Models and dimensions

Dimensions

Indentation for slotted shallow-raised countersunk-head tapping screw DIN ISO 7051 pitch 3.9 (on-site)

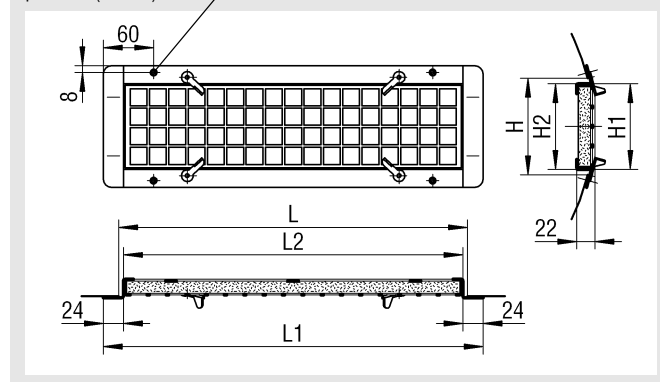

Available sizes KF

L	L1	L2	H	H1	H2
315	352	306	115	102	104
415	452	406	215	202	204
515	552	506			
615	652	606			
815	852	806			

All lengths and heights can be combined!

Installation

Mounting situation

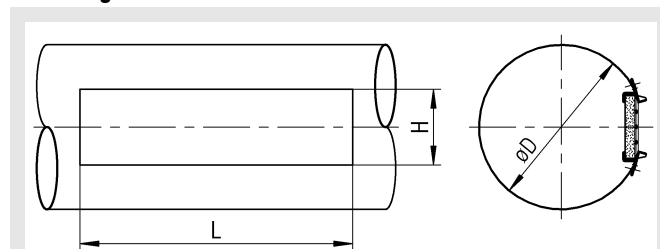

Duct diameter

H (mm)	min.	ideal	øD
115	300	500	800
215	600	750	1250

The grilles frames only make optimum contact when the ideal duct diameter is used.

Duct diameter

The two height dimensions, apart from providing high stability and torsional rigidity, allow optimum adaptation of the filter grille type KF to sheet metal and spiral ducts. The selection of the grille height depends on the duct diameters shown in the table.

Filter Grille KF

Technical Data

Pressure loss and noise level

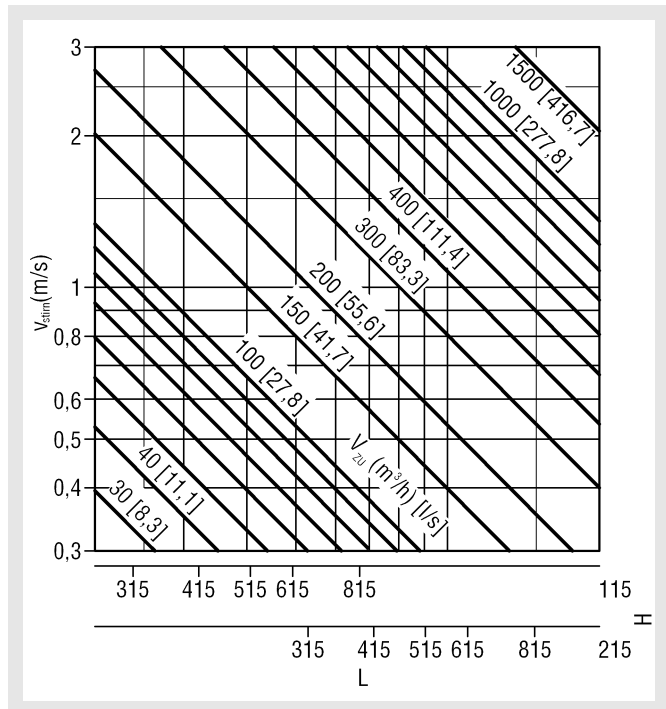

Legend

V_{ZU}	(m ³ /h)	= Supply air volume
V_{ZU}	[l/s]	= Supply air volume
v_{face}	(m/s)	= Intake velocity, blower stream velocity, outflow velocity, relative to A_{face} (L-26 / H-25)
A_{face}	(m ²)	= Face area
ρ	(kg/m ³)	= Density
Δp_t	(Pa)	= Pressure loss
L_{WA}	[dB(A)]	= A-weighted sound power level
KF	(-)	= Correction factor
H	(mm)	= Height
L	(mm)	= Length
L_{WA1}	[dB(A)]	= A-weighted sound power level, relative to $A_{face} = 0.035 \text{ m}^2$

Specification texts

Filter grille for supply and return air consisting of a frame and the filter insert grille made of sheet steel painted to RAL 9010 (white) or of galvanised sheet steel, with fitted and exchangeable dry filter mat made of polyamide fibre.

Fastening with screw mounting (SM).

Product: SCHAKO **type KF**

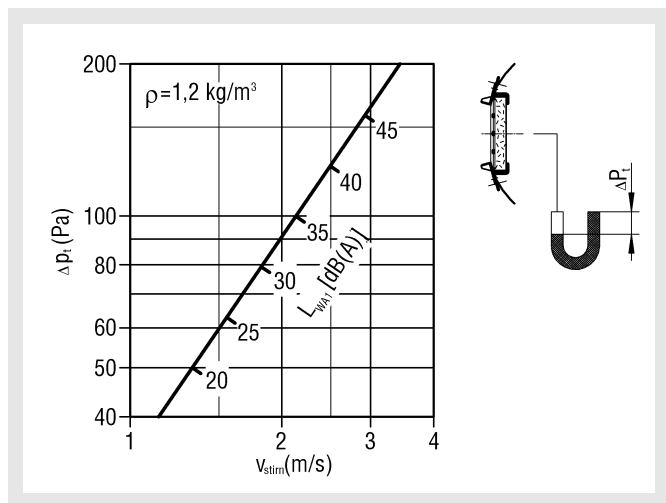

Face area (m²)

H (mm)	L (mm)				
	315	415	515	615	815
115	0,026	0,035	0,044	0,053	0,071
215	0,055	0,074	0,093	0,112	0,150

Correction factor

A_{face} (m ²)	0,017	0,035	0,070	0,140	0,280
KF (-)	-3	0	+3	+6	+9

$$L_{WA} = L_{WA1} + KF$$