



Ceiling Swirl Diffuser

DQJ-SLC



Ferdinand Schad KG
Steigstraße 25-27
D-78600 Kolbingen
Telephone +49 (0) 74 63 - 980 - 0
Fax +49 (0) 74 63 - 980 - 200
info@schako.de
www.schako.de

Ceiling Swirl Diffuser DQJ-SLC

Contents

Description	3
Construction	3
Accessories	3
Fastening	3
Models and dimensions	4
Throw pattern	4
Dimensions	5
Dimensions of accessories	6
Fastening methods	6
Technical Data	7
Pressure loss and noise level	7
Maximum end velocity of jet (isotherm)	11
Critical throw (cooling mode)	12
Temperature and induction ratios	13
Legend	13
Order details	14
Specification texts	15

Ceiling Swirl Diffuser DQJ-SLC

Description

The ceiling swirl diffuser type DQJ-SLC developed for use in comfort rooms is suitable for mounting heights of up to 4 m. It is provided with **an external diffuser ring, which deflects part of the supply air horizontally**. The horizontal throw **forms an air cushion along the ceiling**. This air cushion **keeps any dust particles** contained in the room air **away from the ceiling**. As a result, soiling of the ceiling is reduced.

The laminar flow exiting through the perforated plate is guided by the support jet created by the blades. The blades can be adjusted to achieve a **high-induction or an increased multi-directional throw**. Part of the air of the high-induction jet exits vertically. This increases induction while the temperature and velocity are effectively reduced. In contrast, with the increased multi-directional throw, the air of the laminar flow is deflected horizontally by the horizontal support jet. This produces an increased multi-directional throw, resulting in a long throw.

Both throw patterns can be set ex works. Unless stated otherwise in the order, the high-induction multi-directional throw will be set.

The stability of the air jet prevents the jet from becoming detached from the ceiling, even if the volumetric flow is low. This makes this diffuser also suitable for systems with variable volumetric flow (VAV).

A volumetric flow meter can be integrated in the connection piece of the plenum box at an extra charge. The measurement error of the volumetric flow meter is $\pm 5\%$ at a connection pipe velocity of 2-5 m/s and a straight flow pattern of at least $1 \times D$. The measurement is carried out with mounted diffuser. By adjusting the throttle damper, the required air volume of each diffuser can be set quickly and correctly. For plenum boxes type SRK, the ceiling diffuser must be removed, before the damper can be adjusted. Alternatively, a cable-operated adjustment can be ordered at an extra charge, which allows the damper to be adjusted on the room side even with mounted diffuser.

To allow duct cleaning robots to be inserted from the room side, the diffusion plate, the throttle damper (if built-in) and the volumetric flow meter can be removed in the ROB version of the plenum box SAK / SRK.

Construction

Nozzle part

- sheet steel painted to the RAL colour of the faceplate (sizes 125 - 250)
- Aluminium painted to the RAL colour of the faceplate (size 315)

Faceplate

- Sheet steel painted to RAL 9010 (white)
- Sheet steel painted to a different RAL colour (at an extra charge)

Blades

- Plastic, RAL colour 9010 (white) or RAL 9005 (black)
- Aluminium painted to the RAL colour of the faceplate (blades cannot be adjusted subsequently)

Accessories

Plenum box (-SRK)

- Galvanised sheet steel

Damper (-DV)

- only for connection to flexible ducts

Throttle damper (-DK)

- Damper made of galvanised sheet steel
- Damper fastening made of plastic
- with cable-operated adjustment (-SZV) (at an extra charge)

Rubber lip seal (-GD)

- Special rubber

Panelled cover plate (-PA)

- Sheet steel painted to RAL 9010 (white)

Volumetric flow meter (-VME)

- Mounting made of galvanised sheet steel
- Measuring sensor made of plastic
- Aluminium connections.

Internal insulation (-li)

- Thermal insulation inside the plenum box

External insulation (-la)

- Thermal insulation on the outside of the plenum box

Fastening

Screw mounting (-SM)

- Only possible in combination with the panelled cover plate (-PA). Screws must be provided on-site.

Concealed mounting (-VM, standard)

- A separate counter pole brace for fastening the ceiling swirl diffuser must be fitted when ordered without a plenum box.

Ceiling Swirl Diffuser DQJ-SLC

Models and dimensions

Throw pattern

Blade adjustments

"increased horizontal multi-directional throw"

- all blades in position 2

"high-induction" horizontal multi-directional throw

- The high-induction multi-directional throw is set ex works.

Blade position 1

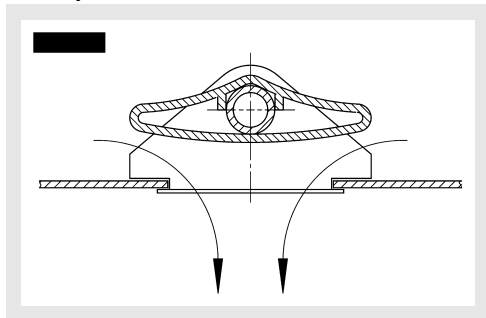

Blade position 2

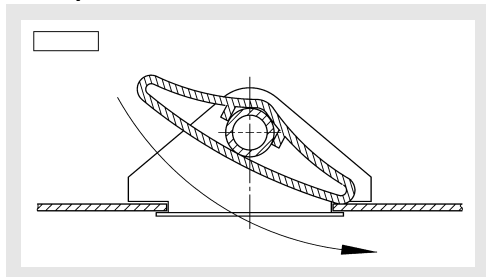

DQJ-SLC 125

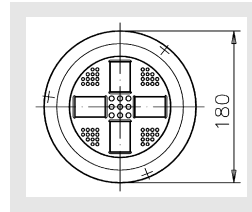

DQJ-SLC 125 only available with increased horizontal multi-directional throw

DQJ-SLC 160

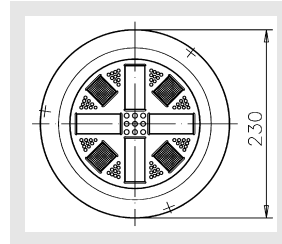

DQJ-SLC 200

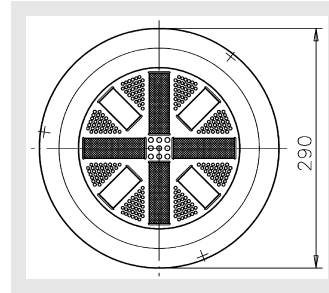

DQJ-SLC 250

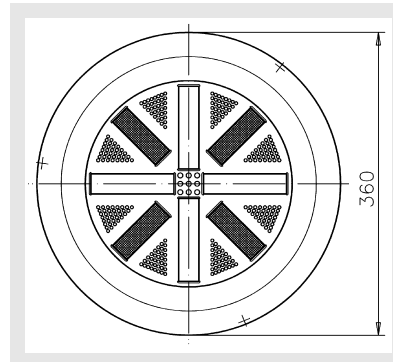

DQJ-SLC 315

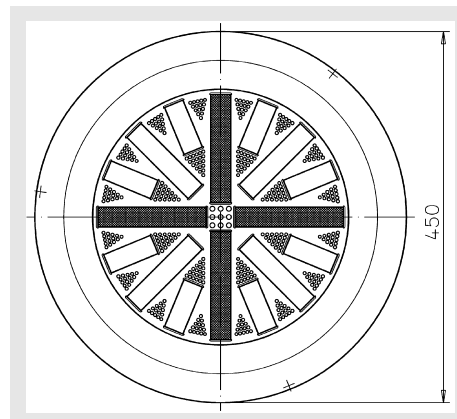

Ceiling Swirl Diffuser DQJ-SLC

Dimensions

DQJ-SLC with plenum box SRK-Z, with concealed mounting (-VM)

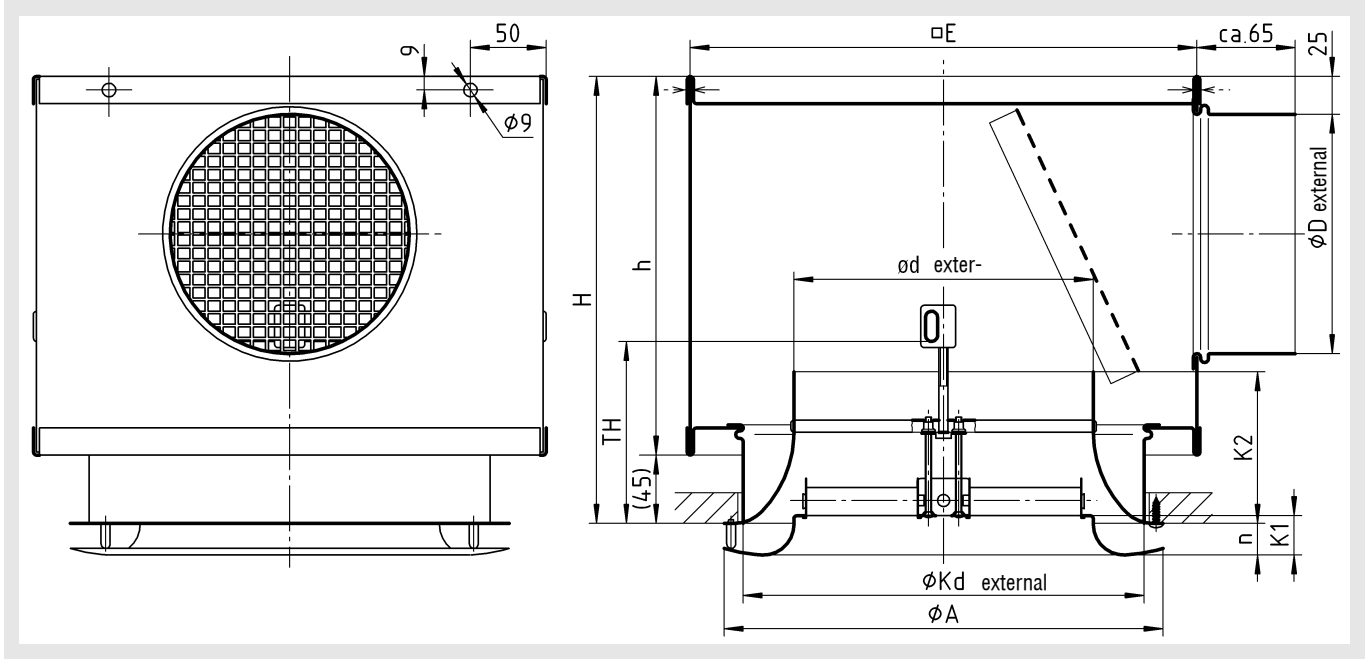

DQJ-SLC, connection to flexible ducts

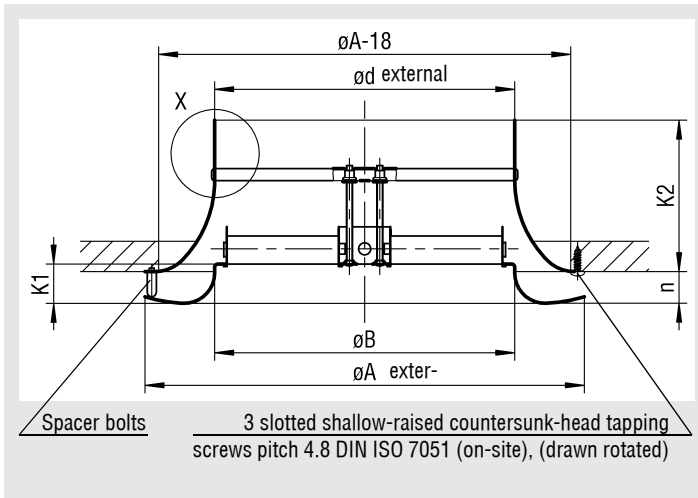

Available sizes

NW	øA	øB = ød	K1	K2	n	øKd	E	H	øD	h	TH
125	180	123	16	60	19,5	158	245	260	123	215	90
160	230	158	21	80	20,6	198	290	295	158	250	100
200	290	198	26	100	21,0	265	335	295	158	250	120
250	360	248	33	125	22,5	335	405	335	198	290	140
315	450	313	41	160	23,1	425	545	385	248	340	190

Ceiling Swirl Diffuser DQJ-SLC

Dimensions of accessories

(at an extra charge):

Volumetric flow meter (-VME)

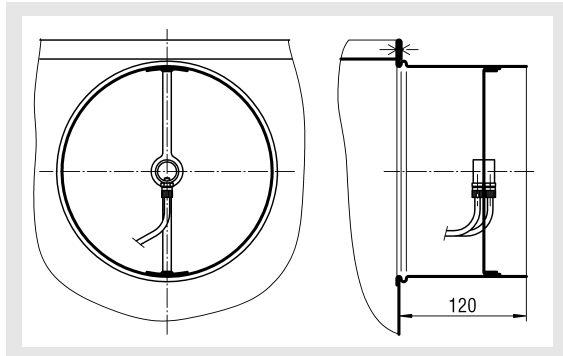

Damper (-DK) with cable-operated adjustment (-SZV)

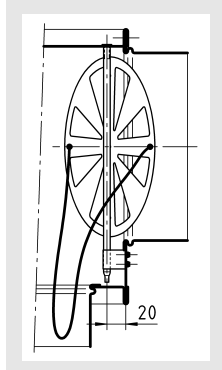

Rubber lip seal (-GD) Detail X

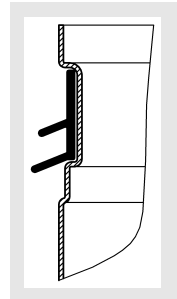

Insulation for SRK inside (-li)

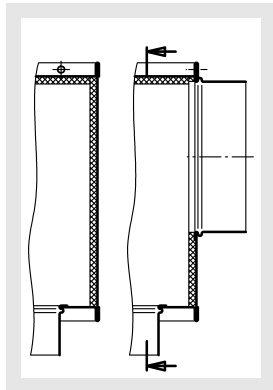

external (-la)

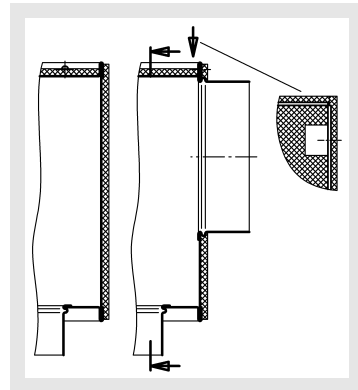

Damper (-DV)

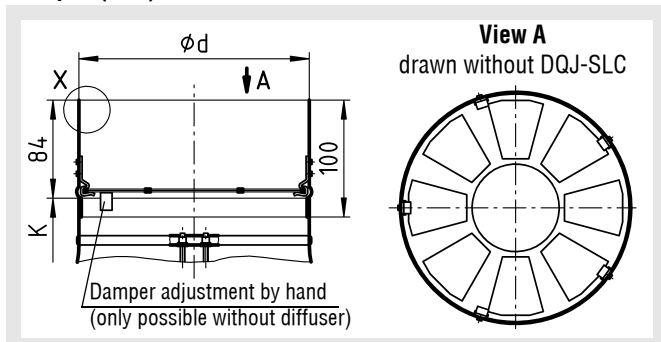

Panelled cover plate (-PA)

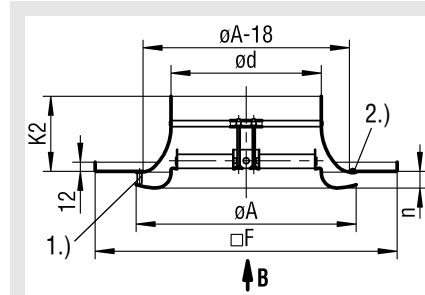

- 1.) 3 distance bolts (drawn rotated)
- 2.) Rivet joint (drawn rotated)

View B PA 310

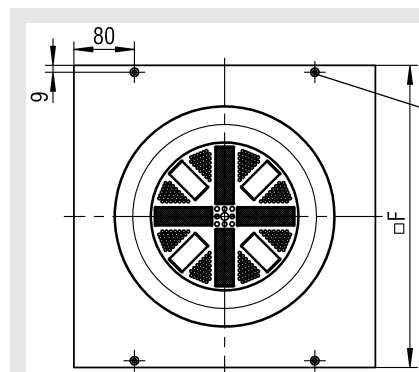
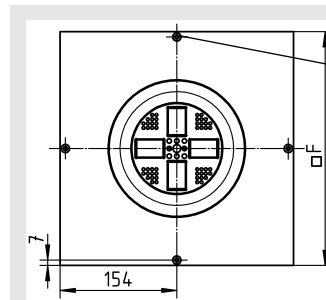

Available sizes

NW	PA	$\square F$	ϕA	ϕd	n	K2
125 - 160	310	308	180	123	19,5	60
125 - 250	400	398	230	158	20,6	80
125 - 315	500	498	290	198	21,0	100
	600	598	360	248	22,5	125
	625	623	450	313	23,1	160

Fastening methods

In concealed mounting (VM), the ceiling swirl diffuser type DQJ-SLC is fastened to the plenum box type SRK-Z by means of a pole brace and an Allen screw DIN EN ISO 4762 M6.

A separate counter pole brace for fastening the ceiling swirl diffuser must be fitted when ordered without a plenum box.

Screw mounting only possible in combination with a panelled cover plate.

Ceiling Swirl Diffuser DQJ-SLC

Technical Data

Pressure loss and noise level

without damper / without plenum box

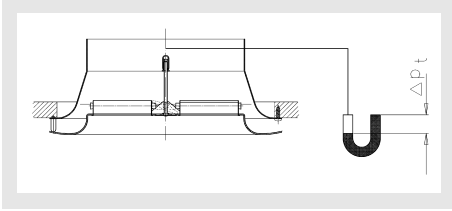

with damper DV / without plenum box

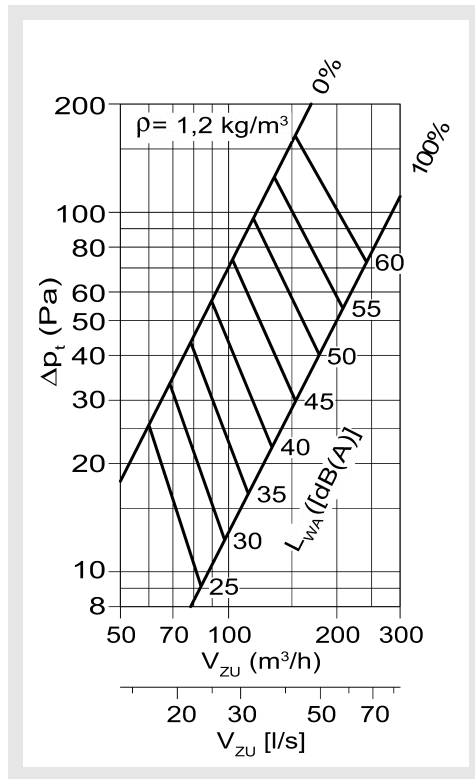
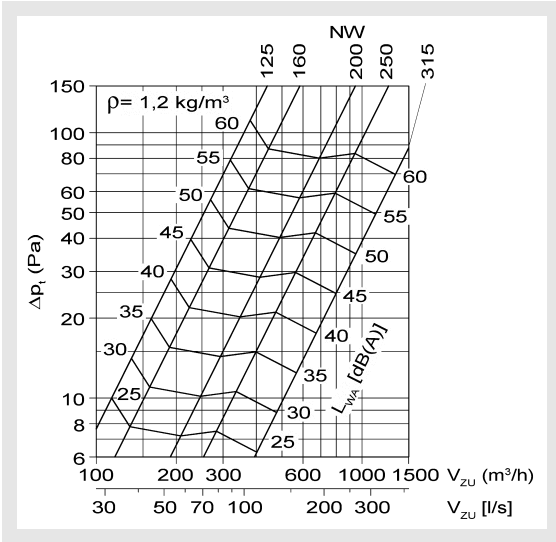
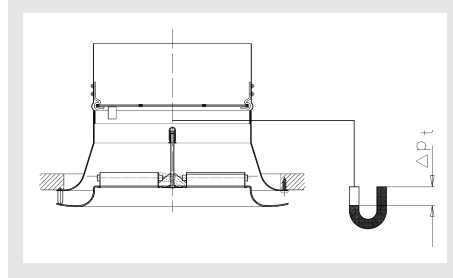

Damper position DV:

- OPEN = 100%
- CLOSED = 0%

Ceiling Swirl Diffuser DQJ-SLC

DQJ-SLC 160-DV

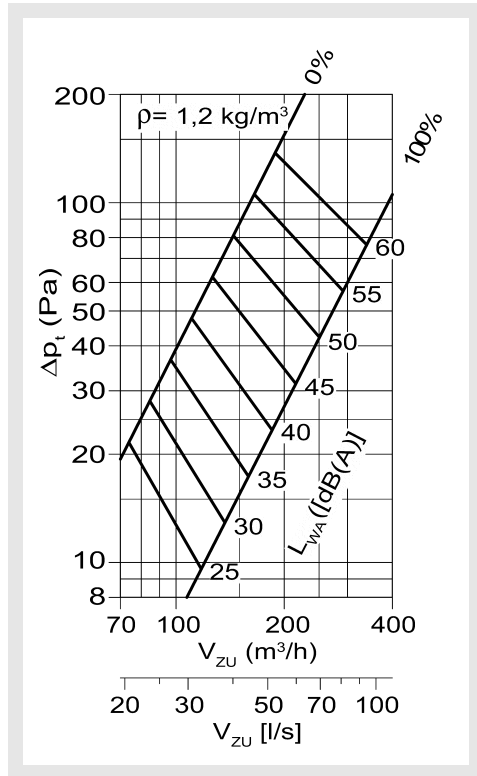

DQJ-SLC 250-DV

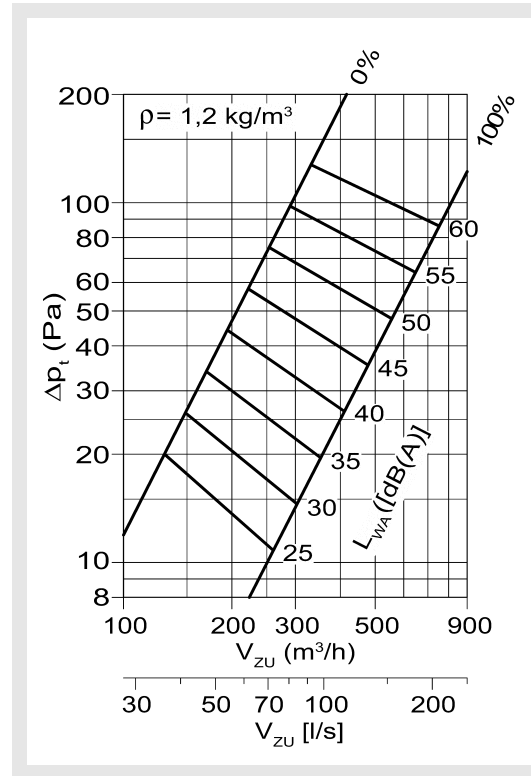

DQJ-SLC 200-DV

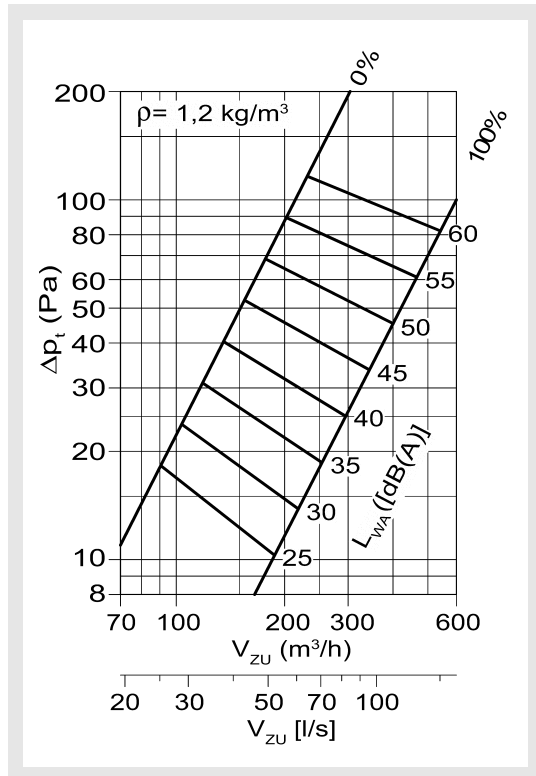

DQJ-SLC 315-DV

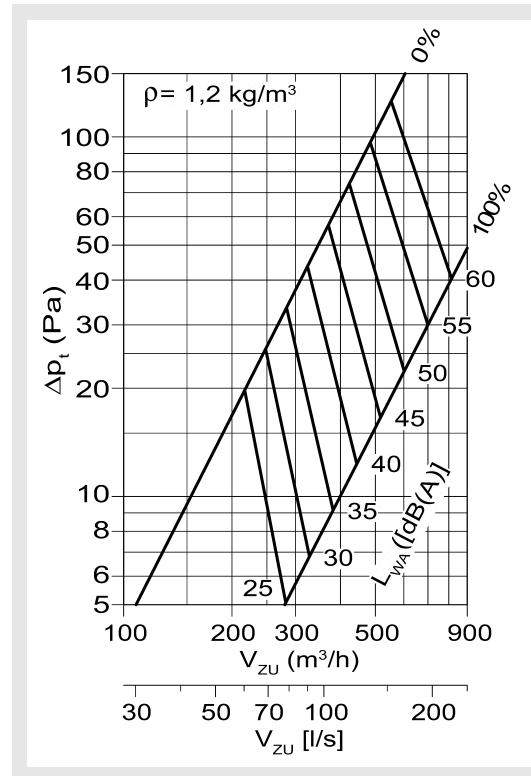

Damper position DV:

OPEN = 100%

CLOSED = 0%

Ceiling Swirl Diffuser DQJ-SLC

with plenum box SRK-Z / with damper DK

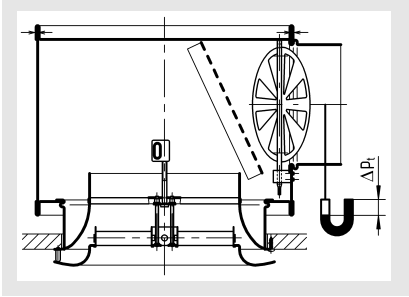

Damper position DK:

OPEN = 100%

CLOSED = 0%

DQJ-SLC 125-SRK-Z-DK

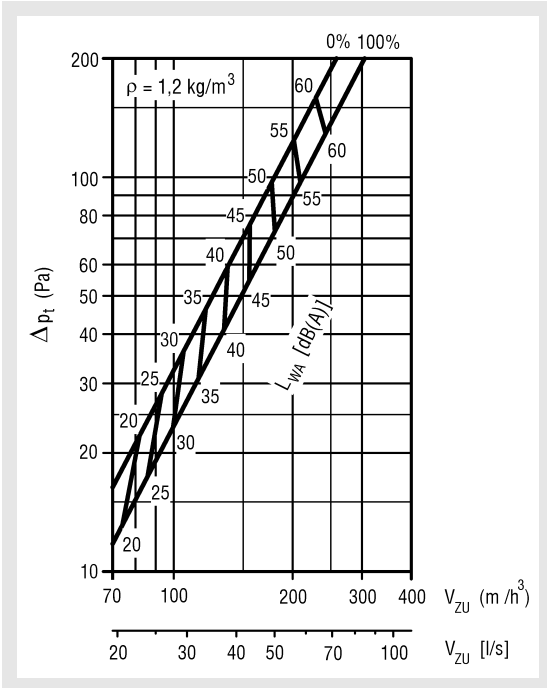

DQJ-SLC 200-SRK-Z-DK

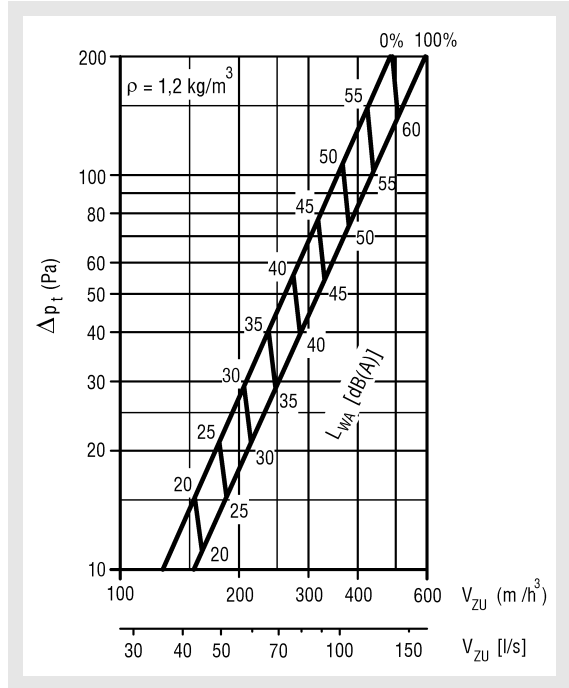

DQJ-SLC 160-SRK-Z-DK

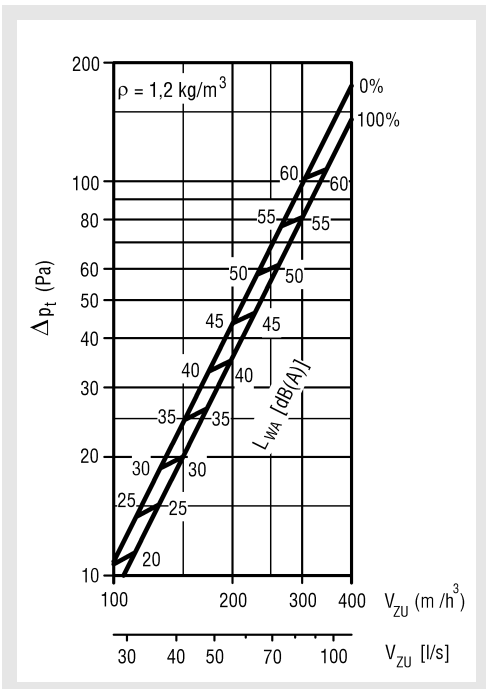

DQJ-SLC 250-SRK-Z-DK

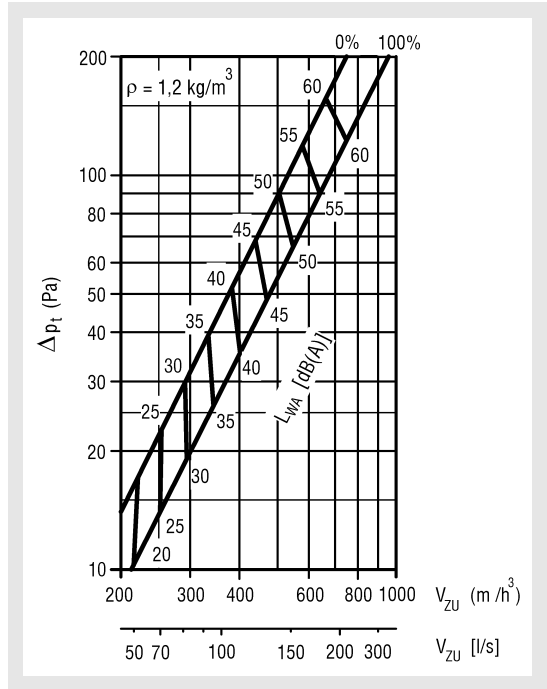

Ceiling Swirl Diffuser DQJ-SLC

DQJ-SLC 315-SRK-Z-DK

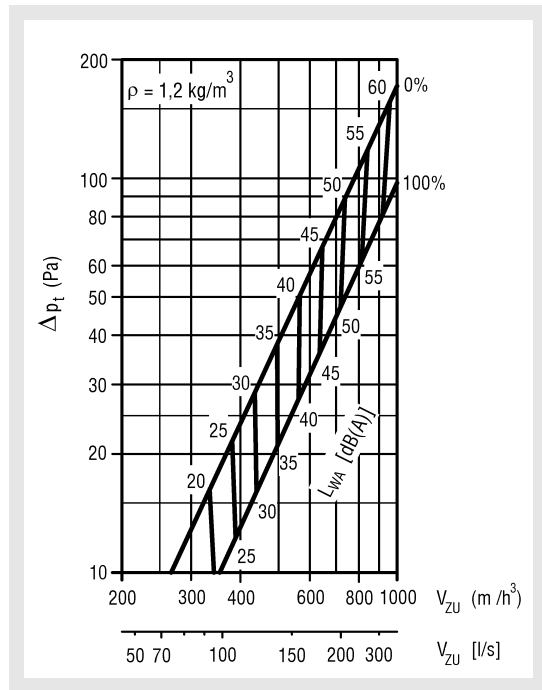

Damper position DK:

OPEN = 100%
CLOSED = 0%

Ceiling Swirl Diffuser DQJ-SLC

Maximum end velocity of jet (isotherm)

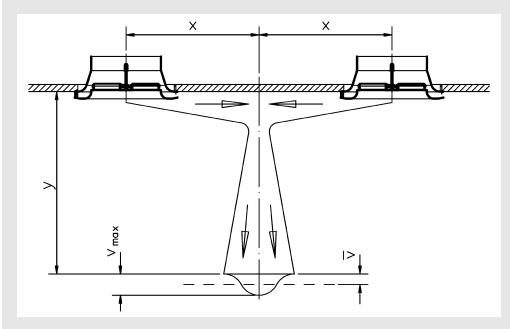

increased horizontal multi-directional

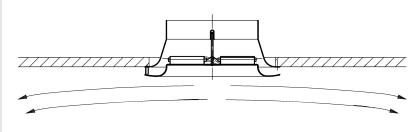

high-induction horizontal multi-directional

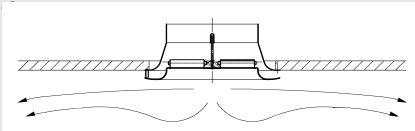

$$V_{\max \text{ increased}} = V_{\max \text{ high-induction}} \times 1.5$$

DQJ-SLC 125, increased horizontal multi-directional throw

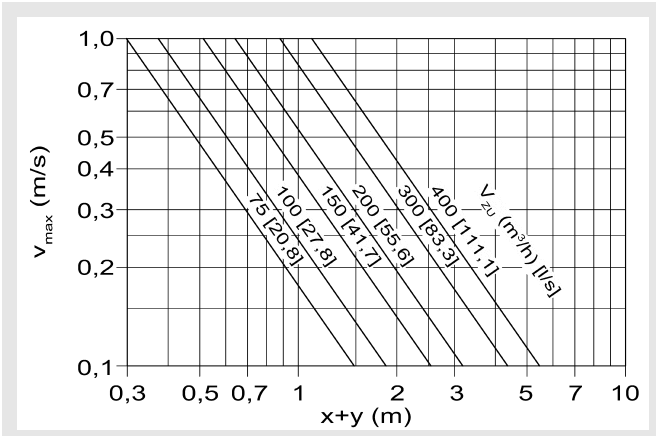

DOJ-SLC 125 only available with increased horizontal multi-directional throw

DQJ-SLC 160, high-induction horizontal multi-directional throw

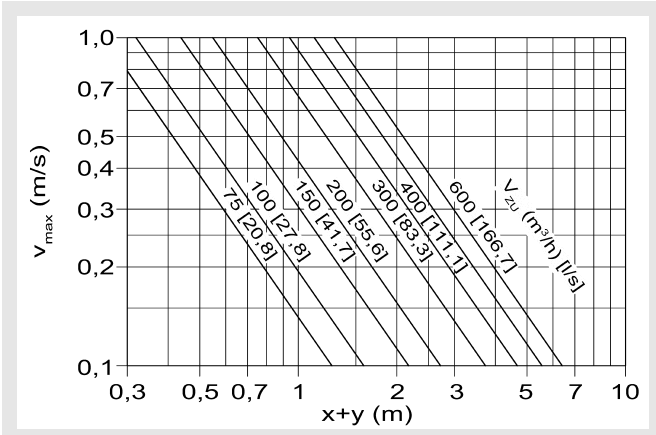

DQJ-SLC 200, high-induction horizontal multi-directional throw

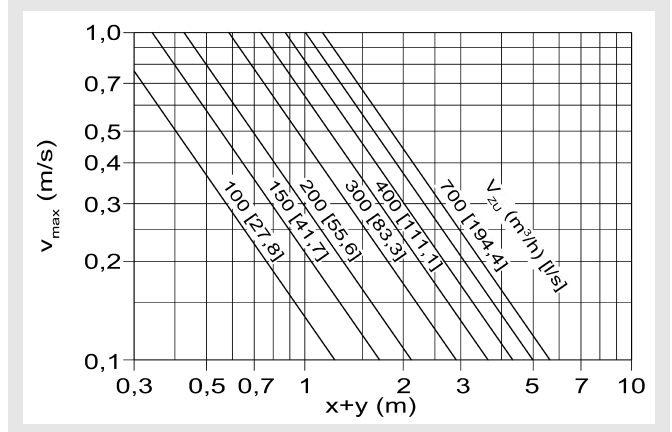

DQJ-SLC 250, high-induction horizontal multi-directional throw

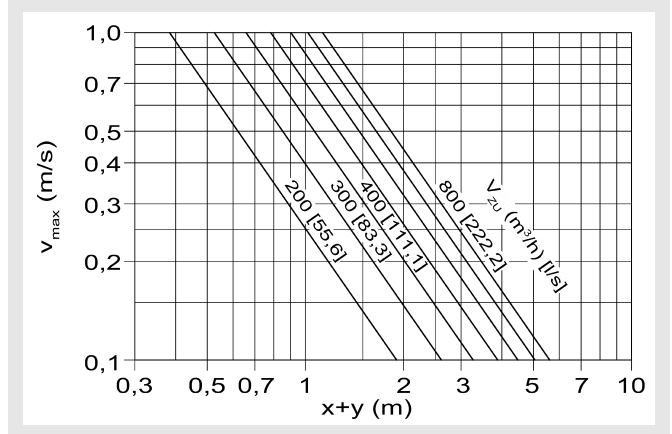

DQJ-SLC 315, high-induction horizontal multi-directional throw

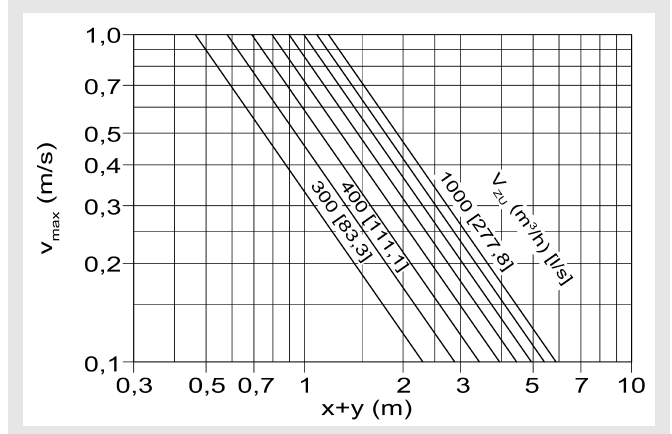

Ceiling Swirl Diffuser DQJ-SLC

Critical throw (cooling mode)

increased horizontal multi-directional throw

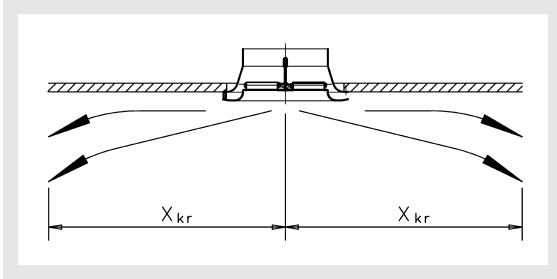

high-induction horizontal multi-directional throw

increased horizontal multi-directional throw = diagram value x 1.25

DQJ-SLC 200

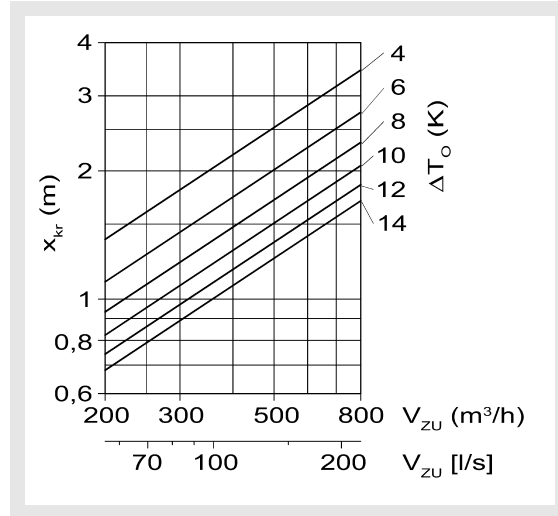

DQJ-SLC 125

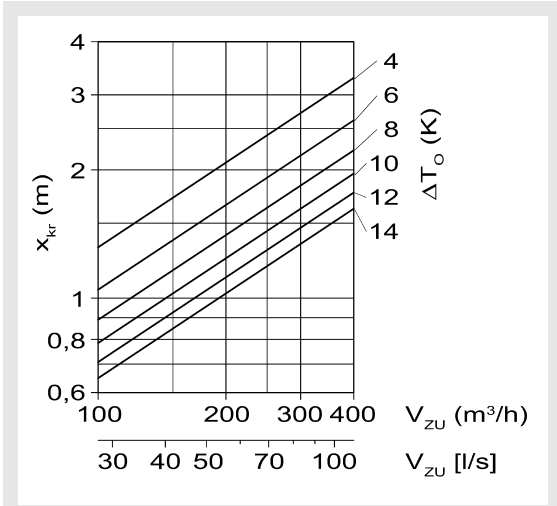

DQJ-SLC 125 only available with increased horizontal multi-directional throw

DQJ-SLC 250

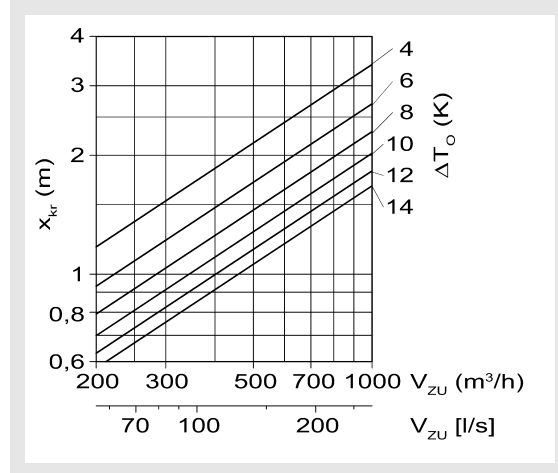

DQJ-SLC 160

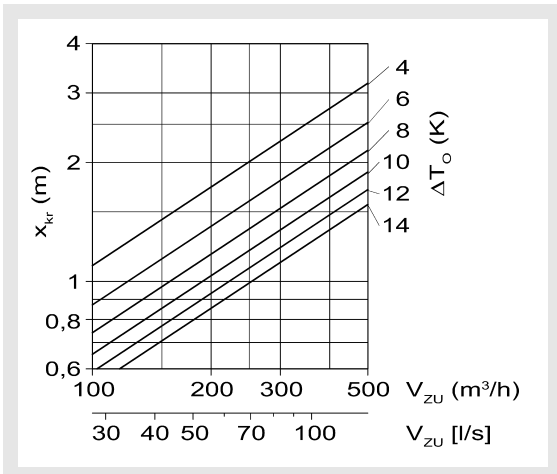

DQJ-SLC 315

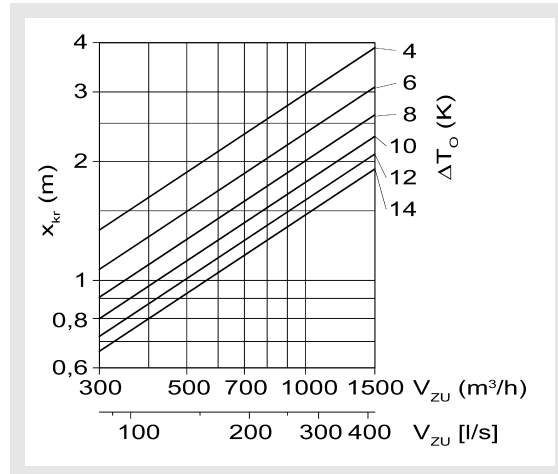

Ceiling Swirl Diffuser DQJ-SLC

Temperature and induction ratios

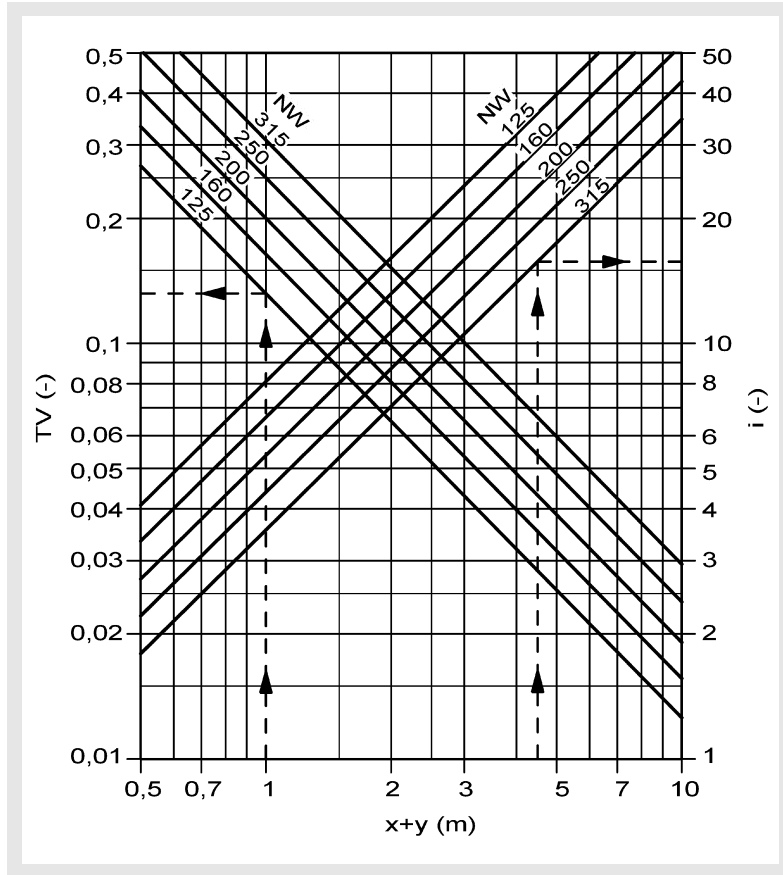

Legend

V_{ZU} (m ³ /h) [l/s]	= Supply air volume
V_X (m ³ /h) [l/s]	= total air jet volume at point x
TV (-)	= Temperature ratio (TV = $\Delta T_X / \Delta T_0$)
i (-)	= Induction ratio (i = V_X / V_{ZU})
x_{kr} (m)	= Critical throw
ΔT_0 (K)	= Temperature difference between supply air temperature and room temperature ($\Delta T_0 = t_{ZU} - t_R$)
ΔT_X (K)	= Temperature difference at point x
t_{ZU} (°C)	= Supply air temperature
t_R (°C)	= Room temperature
x (m)	= Horizontal throw
y (m)	= Vertical throw
x+y (m)	= horizontal + vertical throw
v_{max} (m/s)	= Maximum end velocity of jet
$v_{mittl.}$ (m/s)	= Average end velocity of jet ($v_{mittl.} = 0.5 \times v_{max}$)
Δp_t (Pa)	= Pressure loss
L_{WA} [dB(A)]	= A-weighted sound power level
ρ (kg/m ³)	= Density
NW (mm)	= Nominal width

Ceiling Swirl Diffuser DQJ-SLC

Order details

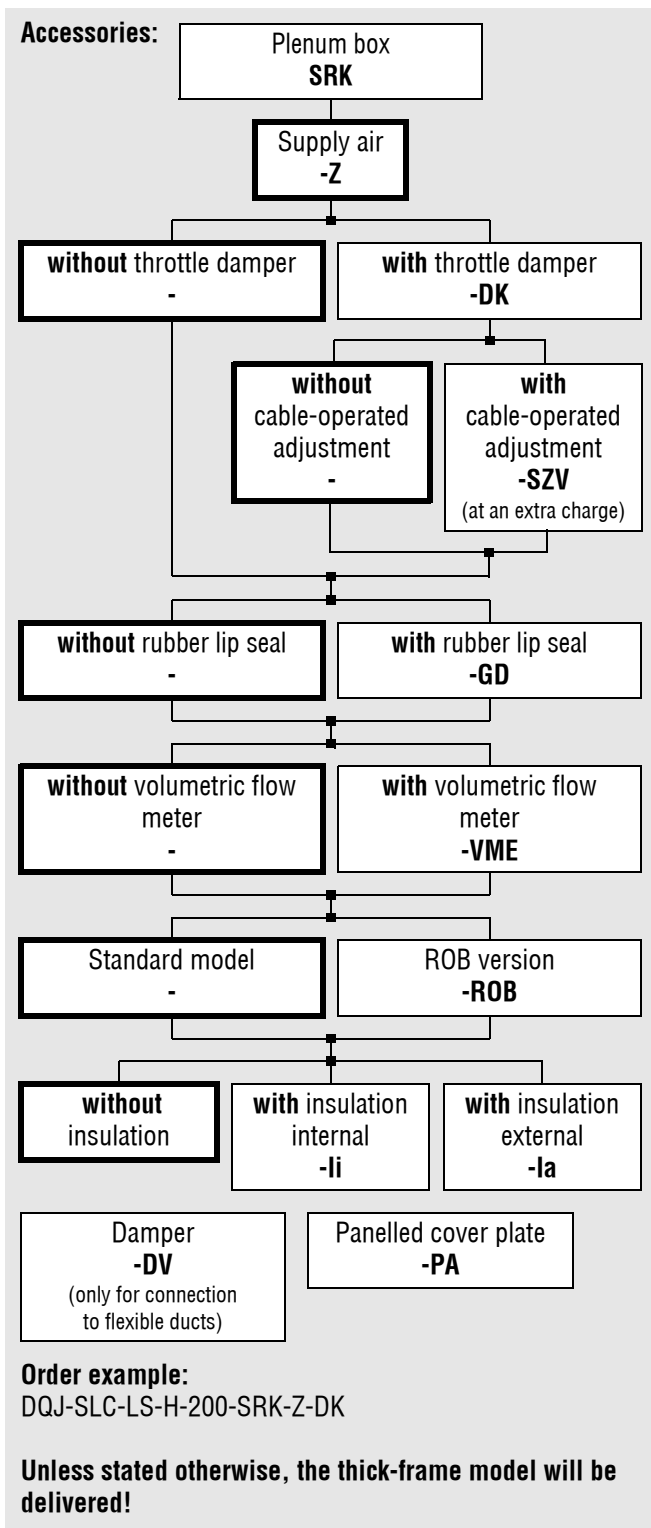
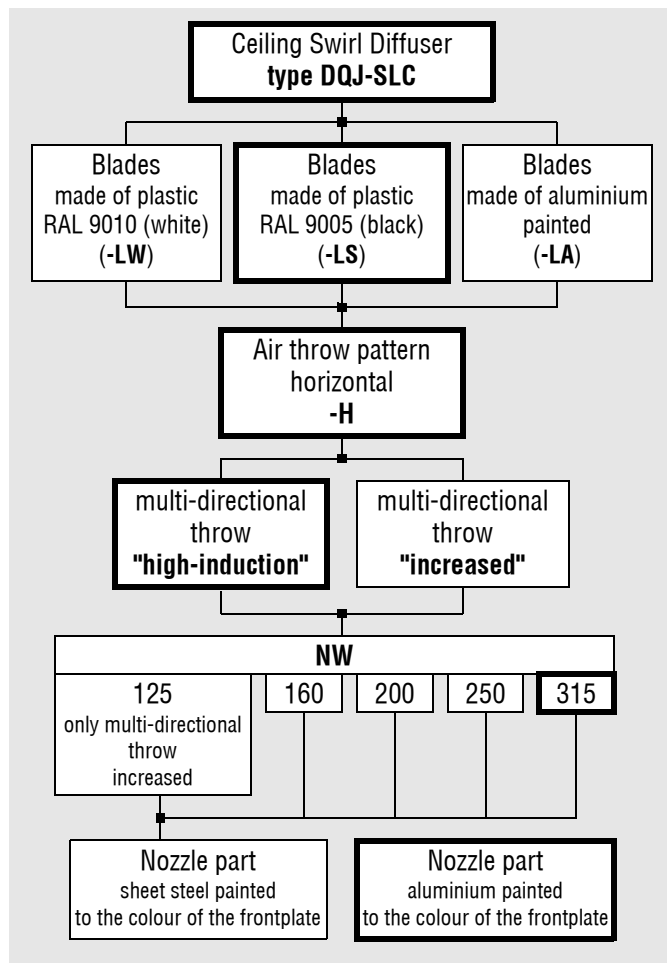

Order example:
DQJ-SLC-LS-H-200-SRK-Z-DK

Unless stated otherwise, the thick-frame model will be delivered!

Ceiling Swirl Diffuser DQJ-SLC

Specification texts

The patented ceiling swirl diffuser type DQJ-SLC in round design with an external diffuser ring to avoid soiling on the ceiling. Particularly suitable for comfort rooms and for VAV systems having variable volumetric flows (between 40 and 100%). Consisting of a perforated faceplate made of sheet steel and nozzle part made of sheet steel (sizes 125 - 250) or aluminium (size 315), both provided with a high-quality powder coating in a RAL colour (RAL 9010, white, standard), with central pivoting, aerodynamic radially fitted air deflection blades, which are individually adjustable, without any tools, from the diffuser front side without dismantling the diffuser, in support profile design made of plastic RAL 9010 (white), RAL 9005 (black) or aluminium, painted individually or to the same RAL colour as the faceplate (subsequent adjustment of blades not possible). Free cross-section, resistance and sound power level constant in all blade positions. Throughput of significantly higher volumetric flows possible with less pressure loss, identical sound power and comparable parameters compared with swirl diffusers without perforation. Fastening by concealed mounting (VM), made of aerodynamic aluminium profile.

Product: SCHAKO **type DQJ-SLC**

Throw patterns:

- high-induction horizontal multi-directional throw (only sizes 160 - 315)
- increased horizontal multi-directional throw

Accessories:

- with plenum box (-SRK-Z) made of galvanised sheet steel with lateral connection piece and fixing lugs.
 - with a throttle damper (-DK) adjustable at the front side in the plenum box for air volume regulation
 - with cable-operated adjustment (-SZV)
 - with volumetric flow meter (-VME)
 - with ROB version (-ROB), removable diffuser plate, throttle damper and volumetric flow meter.
 - with rubber lip seal (-GD), made of special rubber, at the connection pipe.
 - with thermal insulation
 - internal (-li)
 - external (-la)
- with damper (-DV, for connection to flexible ducts only)
- Panelled cover plate (-PA) made of sheet steel painted to RAL 9010 (white) with screw mounting (-SM).