



Round Duct Diffuser

DBB-RR



Ferdinand Schad KG
Steigstraße 25-27
D-78600 Kolbingen
Telephone +49 (0) 74 63 - 980 - 0
Fax +49 (0) 74 63 - 980 - 200
info@schako.de
www.schako.de

Round Duct Diffuser Model DBB-RR

Contents

Description	3
Construction	3
Model	3
Accessories	3
Fastening	3
Blade adjustment options	4
Blade position	4
Models and dimensions	5
Dimensions	5
Accessories	6
Technical Data	7
Pressure loss and noise level	7
Maximum end velocity of jet	8
Maximum penetration	8
Temperature ratio	8
Induction ratio	8
Legend	9
Order details	9
Specification texts	10

Round Duct Diffuser Model DBB-RR

Description

In modern architecture, sheet metal and spiral ducts of air-conditioning systems are often incorporated in the design of the room. Emphasis is often placed deliberately on parts of the supply system. In this visible installation of the ventilation ducts, it is a good idea to integrate the air diffusers into the ducts.

In order to be able to offer planners a technically advanced air diffuser, which can also be well integrated into modern architectural concepts, we have developed our round duct diffuser type DBB-RR.

The diffuser type DBB-RR consists of a **round duct with integrated, linear nozzles, which can also be adjusted by hand on-site**, with integrated hit-and-miss damper, which allows the air to be blown absolutely uniformly over the entire diffuser area. The centrally arranged blades in support profile sections ensure that the free **cross-section at every blade is the same**. As a result, the noise level and pressure are not affected by changing the blade position. **In heating mode**, this allows a **large penetration depth**, thus providing an **effective, cost-saving heating phase**. In cooling mode, the maximum end velocity of jet and temperature difference are reduced to such an extent that **no draughts** are produced **in the occupied zone**.

This uniform admission allows the round duct diffuser type DBB-RR to be installed at any point along the duct system.

Accessories, such as dummy pipes, end covers and connecting sleeves complete the range for this diffuser (See documents: Accessories for round duct systems).

For maintenance, service, retrofitting, etc., inspection openings in sufficient number and size must be provided on-site.

Advantages:

- Sound power level and pressure loss remain constant in all blade positions.
- Dimensionally stable smooth duct is easy to clean.

Construction

Blades

- Plastic RAL 9010 (white) or RAL 9005 (black)
- Aluminium painted to the RAL colour of the faceplate. Painted blades cannot be adjusted afterwards.

Round duct

- galvanised sheet steel
- Sheet steel painted to RAL 9010 (white) (standard)
- Natural aluminium
- Stainless steel 1.4301 (V2A) painted in the colour sand silver

Hit-and-miss damper

- made of the same material as the round duct
 - Galvanised sheet steel
 - Natural aluminium
 - Stainless steel 1.4301 (V2A)

Model

- DBB-RR-Z - Supply air model with air deflection blades.
- DBB-RR-A - Return air model without air deflection blades.

Accessories

- Rubber lip seal
- Other accessories
 - Separate brochure on request

Fastening

Suspension

- prepared for suspended installation by using an M8 threaded rod to be provided by the customer.

Attention!

We would like to point out that only suitable cleaning materials may be used for cleaning the stainless steel design!

In order to avoid corrosion-caused damage, we recommend subjecting the components natural aluminium design on-site to an after-treatment by anodisation or painting.

Please note that for vertical throw a distance of at least 100 mm must be available between the weld seam and the diffuser. This means that the weld seam must be offset accordingly.

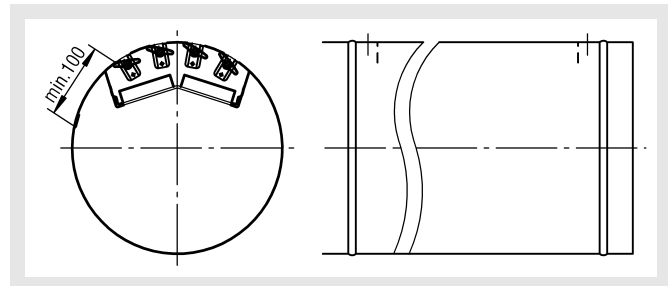

Round Duct Diffuser Model DBB-RR

Blade adjustment options

Throw directions (blade position 6 o'clock)

one-way horizontal (-He)

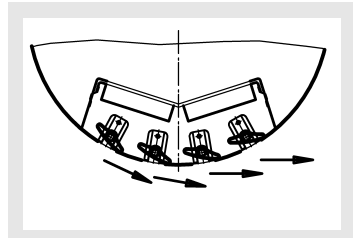

two-way horizontal (-Hb)

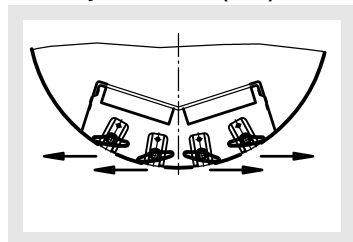

vertical (-V)

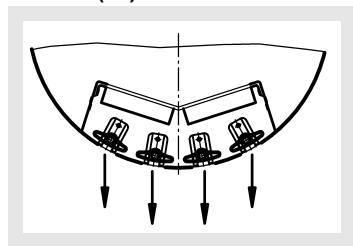

crosswise (-K)

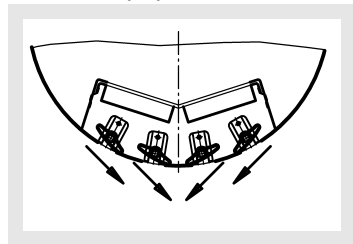

Blade position

6 o'clock (-6U, standard)

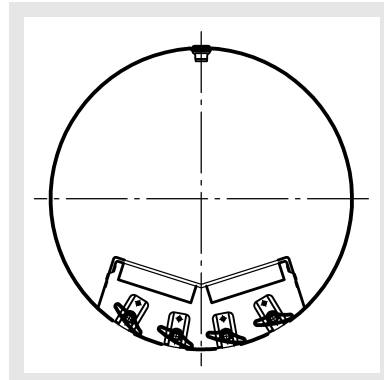

3 o'clock (-3U)

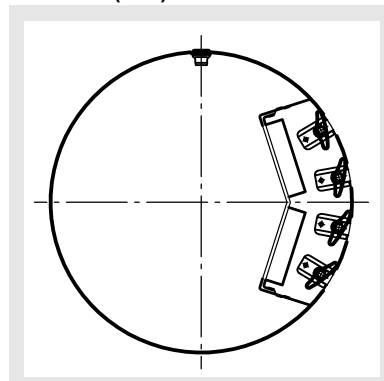

9 o'clock (-9U)

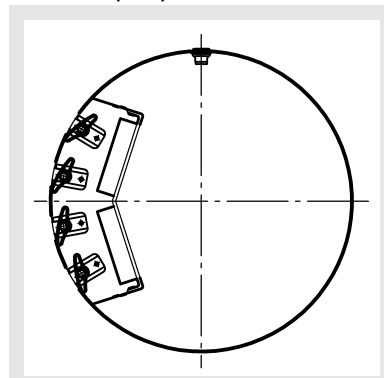

Ex works, the blades are set to the 6 o'clock blade position. On request the blade position "3 o'clock" or "9 o'clock", each in the air flow direction, is also available.

Round Duct Diffuser Model DBB-RR

Models and dimensions

Dimensions

DBB-RR

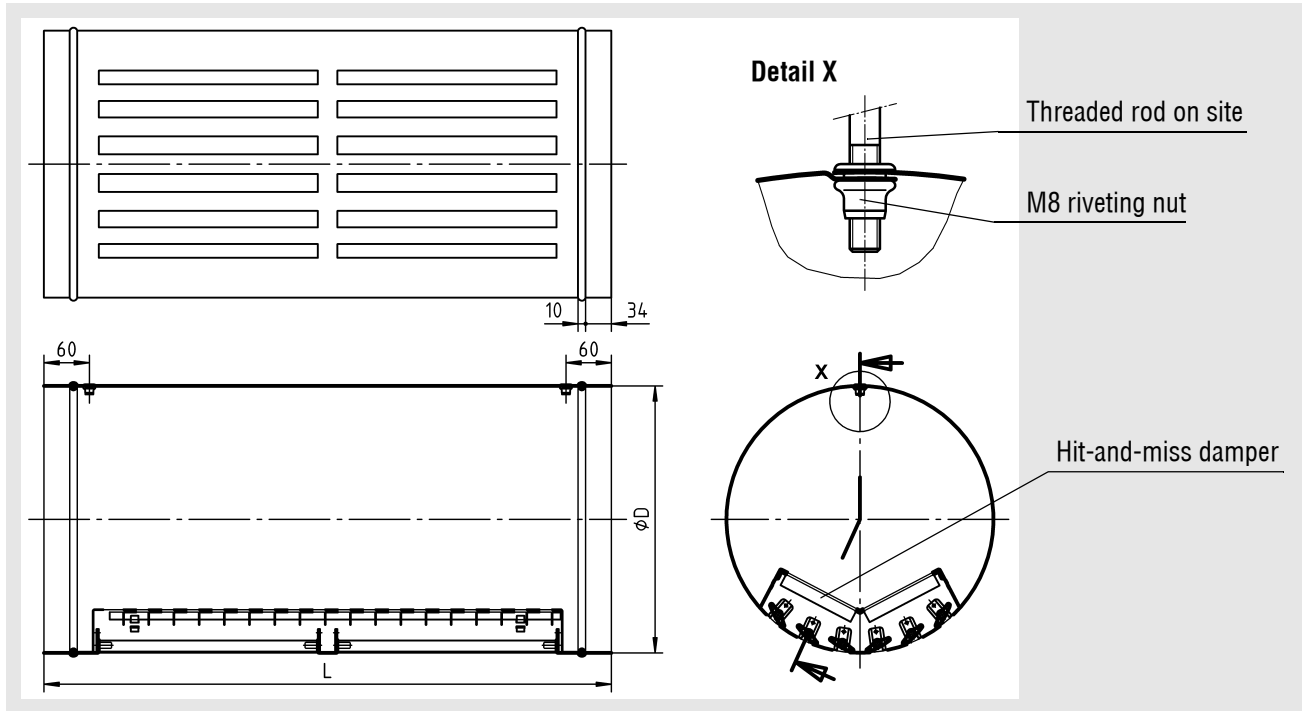

Available sizes

Size	ϕD	Number of slots along circumference							
		2	4	6	8	10	12	14	
200	198	x	x	-	-	-	-	-	
224	222	x	x	-	-	-	-	-	
250	248	x	x	-	-	-	-	-	
280	278	x	x	x	-	-	-	-	
315	313	x	x	x	-	-	-	-	
355	353	x	x	x	x	-	-	-	
400	398	x	x	x	x	-	-	-	
450	448	x	x	x	x	-	-	-	
500	498	x	x	x	x	x	x	x	
560	558	x	x	x	x	x	x	x	
630	628	x	x	x	x	x	x	x	
710	708	x	x	x	x	x	x	x	
800	798	x	x	x	x	x	x	x	
900	898	x	x	x	x	x	x	x	

Length L	Number of slots lengthwise
750	2
1000	3
1500	4
1750	5
2000	6

x = available
 - = not available

Round Duct Diffuser Model DBB-RR

Length of sections

1-part:

Length 500

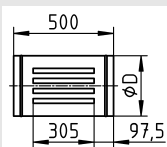

Length 750

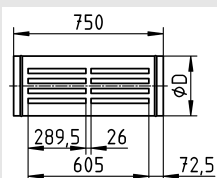

Length 1000

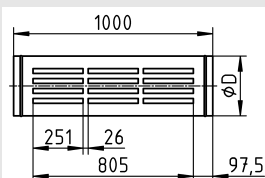

Accessories

- Rubber lip seal

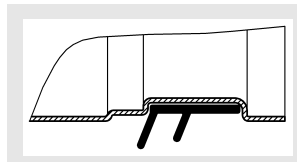

2-part:

Length 1500

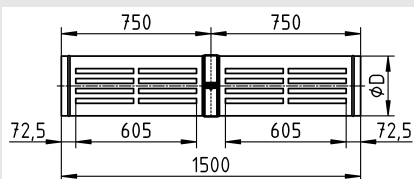

Length 1750

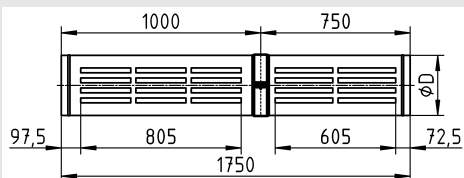

Length 2000

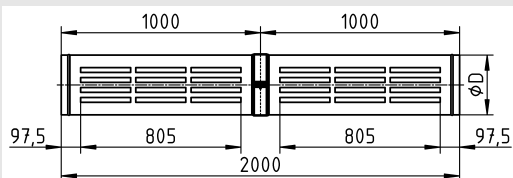

Round duct diffusers having a length of > 1000 are produced in two sections and joined at the factory using a sleeve. The dimensions of the dummy pipe fit the dimensions of the round duct grille type KG-RR.

A different length of sections is possible on request. However, the maximum length for a middle or end piece is 1000 mm.

Round Duct Diffuser Model DBB-RR

Technical Data

Pressure loss and noise level

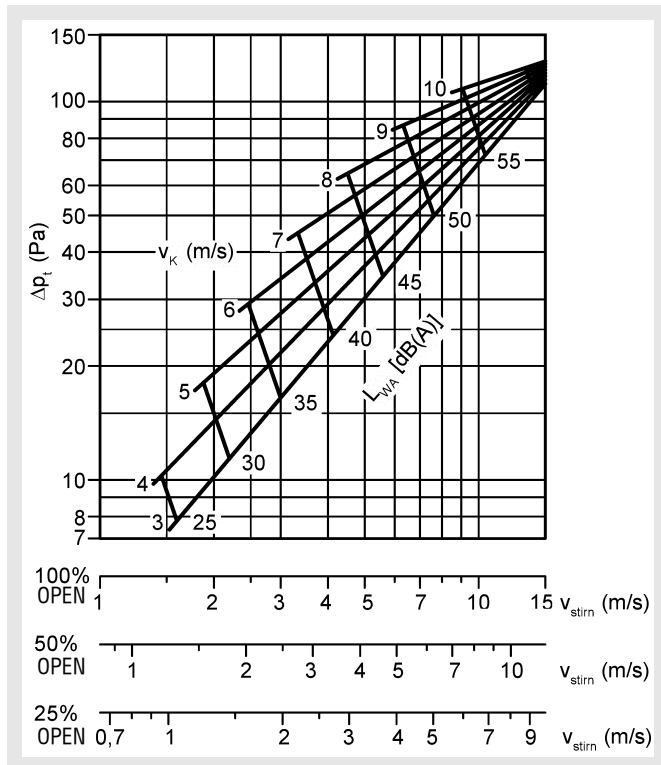

OPEN = hit-and-miss damper position

Correction factor pressure loss and noise level

$$V_{stirn} = V_{ZU} \text{ (m}^3\text{/h)} : (\text{FQ} \times 3600 \times \text{KF})$$

Size	V _{ZU} (at v _k =1 m/s) (m ³ /h) [l/s]		FQ (m ²)						
			Number of slots along circumference						
			2	4	6	8	10	12	14
200	108	30	0,01	0,02	-	-	-	-	-
224	139	39	0,01	0,02	-	-	-	-	-
250	174	48	0,01	0,02	-	-	-	-	-
280	219	61	0,01	0,02	0,03	-	-	-	-
315	277	77	0,01	0,02	0,03	-	-	-	-
355	356	99	0,01	0,02	0,03	0,04	-	-	-
400	448	124	0,01	0,02	0,03	0,04	-	-	-
450	567	158	0,01	0,02	0,03	0,04	-	-	-
500	701	195	0,01	0,02	0,03	0,04	0,05	0,06	0,07
560	978	272	0,01	0,02	0,03	0,04	0,05	0,06	0,07
630	1115	310	0,01	0,02	0,03	0,04	0,05	0,06	0,07
710	1417	394	0,01	0,02	0,03	0,04	0,05	0,06	0,07
800	1801	500	0,01	0,02	0,03	0,04	0,05	0,06	0,07
900	2280	633	0,01	0,02	0,03	0,04	0,05	0,06	0,07

	Length L	KF
1-part	500	x 0.5
	750	x 0.75
	1000	x 1.00
2-part	1500	x 1.5
	1750	x 1.75
	2000	x 2.0

Correction factor pressure loss and noise level

for DBB-RR without hit-and-miss damper

$$L_{WA \text{ 100\% OPEN}} \times 0,877$$

$$\Delta p_{t \text{ 100\% OPEN}} \times 0,78$$

Round Duct Diffuser Model DBB-RR

Maximum end velocity of jet

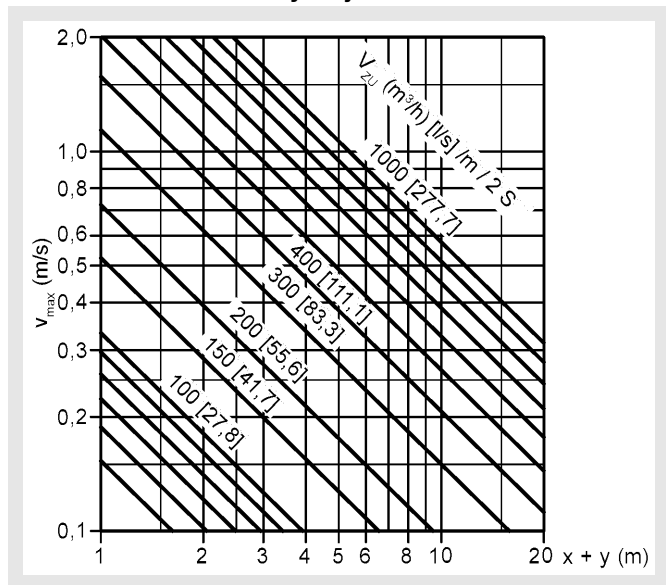

Temperature ratio one-way horizontal throw

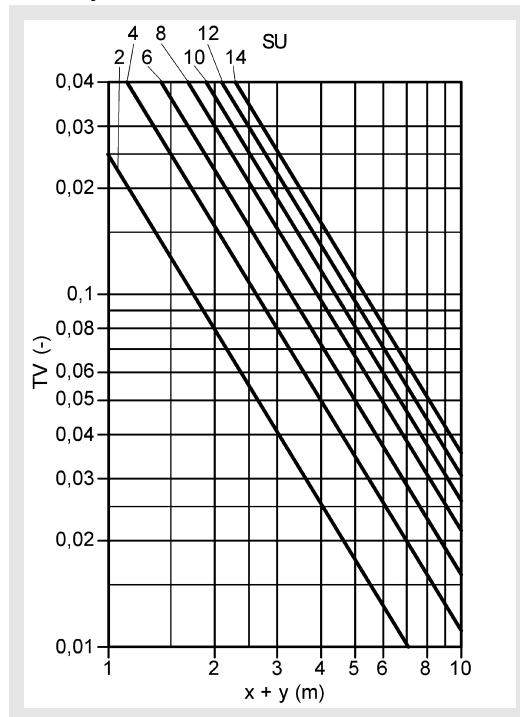

Correction factor Maximum end velocity of jet

	Number of slots along circumference						
	2	4	6	8	10	12	14
one-way horizontal	x1	x1.2	x1.4	x1.68	x2.02	x2.42	x2.88
horizontal left / right	x0.58	x0.72	x0.8	x0.96	x1.17	x1.39	x1.67

Maximum penetration

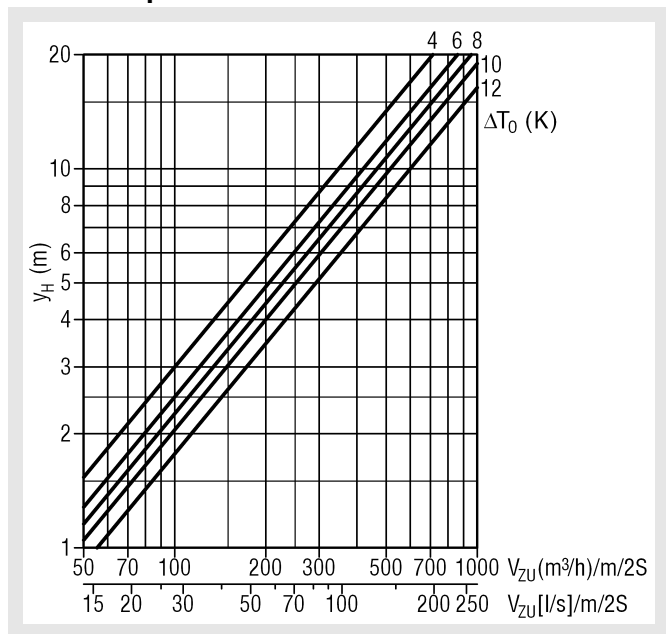

Induction ratio one-way horizontal throw

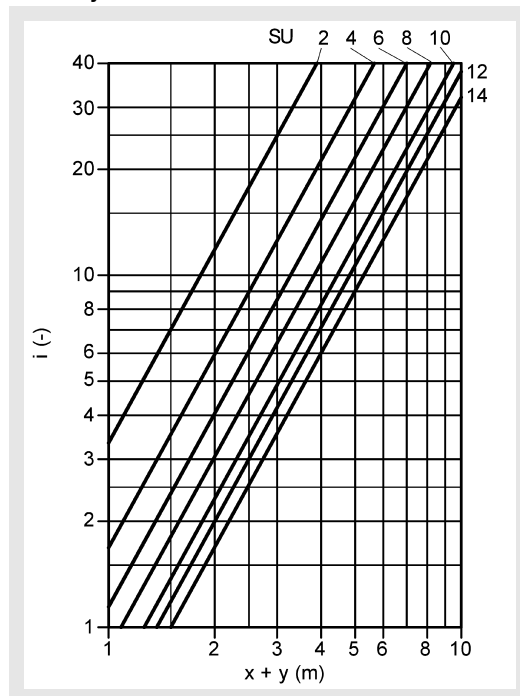

Correction factor max. penetration

	Number of slots along circumference						
	2	4	6	8	10	12	14
vertical	x1	x1.17	x1.36	x1.59	x1.86	x2.18	x2.56
crosswise	x1.2	x1.44	x1.73	x2.08	x2.49	x2.99	x3.58

Round Duct Diffuser Model DBB-RR

Legend

V_{ZU} (m ³ /h/m/2S)	= Supply air volume per meter per 2 slots
V_{ZU} [l/s/m/2S]	= supply air volume per meter per 2 slots
V_x (m ³ /h) [l/s]	= total air jet volume at point x
Δp_t (Pa)	= Pressure loss
v_{stirn} (m/s)	= Intake velocity, blower stream velocity, outflow velocity, relative to A_{stirn}
V_{max} (m/s)	= Maximum end velocity of jet
v_K (m/s)	= Duct velocity
L_{WA} [dB(A)]	= A-weighted sound power level
x+y (m)	= horizontal + vertical throw
y_H (m)	= Maximum penetration in heating mode
ΔT_0 (K)	= Temperature difference between supply air temperature and room temperature ($\Delta T_0 = t_{ZU} - t_R$)
ΔT_x (K)	= Temperature difference at point x
t_{ZU} (°C)	= Supply air temperature
t_R (°C)	= Room temperature
i (-)	= Induction ratio ($i = V_x / V_{ZU}$)
TV (-)	= Temperature ratio ($TV = \Delta T_x / \Delta T_0$)
KF (-)	= Correction factor
FQ (m ²)	= Free cross-section
NW	= Nominal width
SU	= Number of slots along circumference

Order details

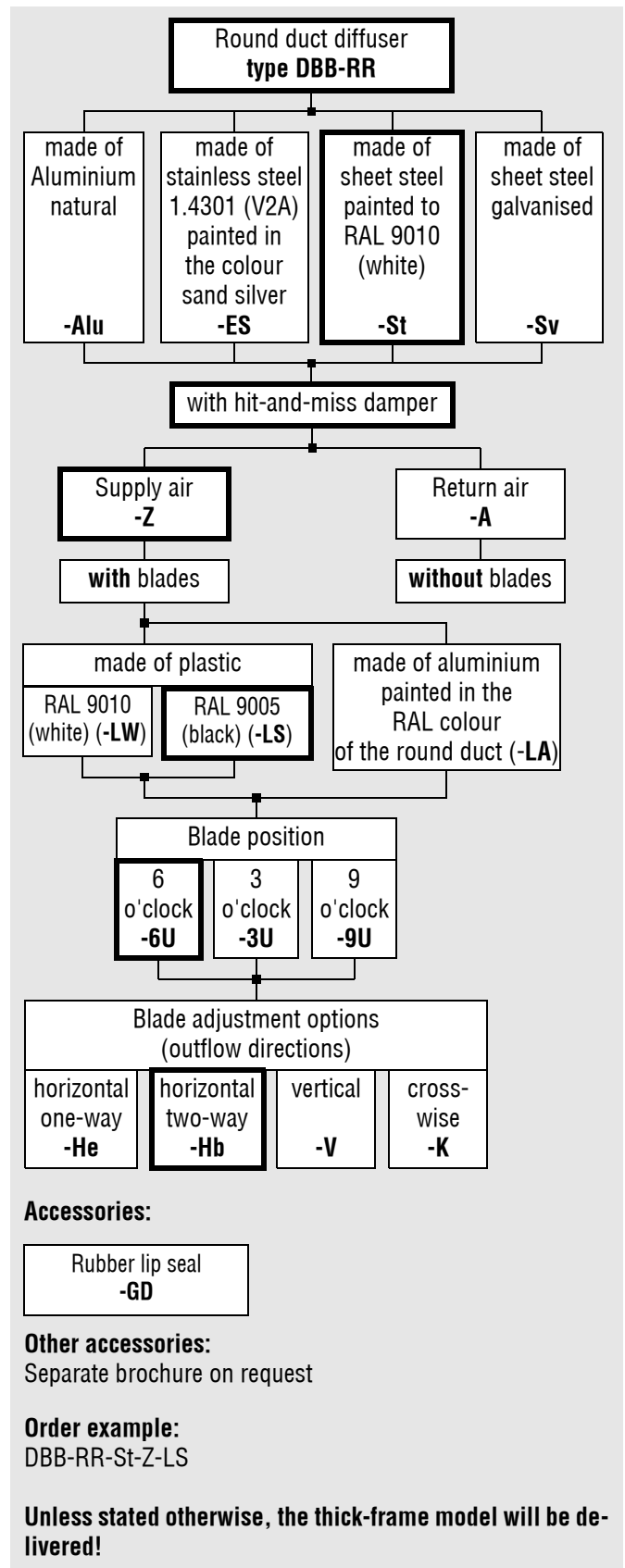

Round Duct Diffuser Model DBB-RR

Specification texts

Round duct diffuser suitable for connection to DIN ducts. With integrated, manually adjustable air deflection blades support blade profile section made of plastic, in colours RAL 9010 (white), RAL 9005 (black) or aluminium painted to the RAL colour of the round duct (blades are not adjustable later on). Noise level and pressure loss remain constant in all blade positions. With integrated hit-and-miss damper for simple air volume regulation and ductwork regulation, made of the material the round duct is made of.

Product: SCHAKO **type DBB-RR-Z.**

- for return air, without air deflection blades
Product: SCHAKO **type DBB-RR-A**

- Round duct made of
 - galvanised sheet steel
 - Sheet steel painted to RAL 9010 (white) (standard)
 - Stainless steel 1.4301 (V2A) painted in the colour sand silver
 - Natural aluminium

- Blade position
 - 3 o'clock (-3U)
 - 6 o'clock (-6U, standard)
 - 9 o'clock (-9U)

- Blade adjustment options (throw directions)
 - one-way horizontal (-He)
 - two-way horizontal (-Hb, standard)
 - vertical (-V)
 - crosswise (-K)

Accessories:

- Rubber lip seal (-GD)
 - Separate brochure on request